



SINGULAIR® BIO-KINETIC®

MODEL 960 WASTEWATER TREATMENT SYSTEM

OWNER'S MANUAL

INTRODUCTION

The Singulair system is the finest equipment available and utilizes the most up-to-date wastewater treatment technology. It is a sound investment that protects you and the environment. Please take the time to familiarize yourself with the contents of this manual.

HOW THE SINGULAIR® SYSTEM WORKS

Developed to serve homes and small businesses beyond the reach of city sewers, the Singulair system employs the extended aeration process. Similar to the treatment method used by most municipal wastewater treatment facilities, this process involves a natural, biological breakdown of the organic matter in wastewater.

Wastewater enters the pretreatment chamber where anaerobic bacterial action combines with the effects of gravity to precondition the waste before it flows into the aeration chamber. Once in the aeration chamber, aerobic bacteria utilize the organic matter in the wastewater to biologically convert the waste into stable substances. Following aeration, flow is transferred to the clarification chamber where the effects of gravity settle out biologically active material. The Bio-Static sludge return, located in the clarification chamber, creates hydraulic currents that gently transfer settled particles back to the aeration chamber. As clarified liquids pass through the Bio-Kinetic system, they are filtered, settled and flow equalized. As a result, complete pretreatment, aeration, clarification and final filtration are assured. The Singulair system reliably protects you, your property and the environment.

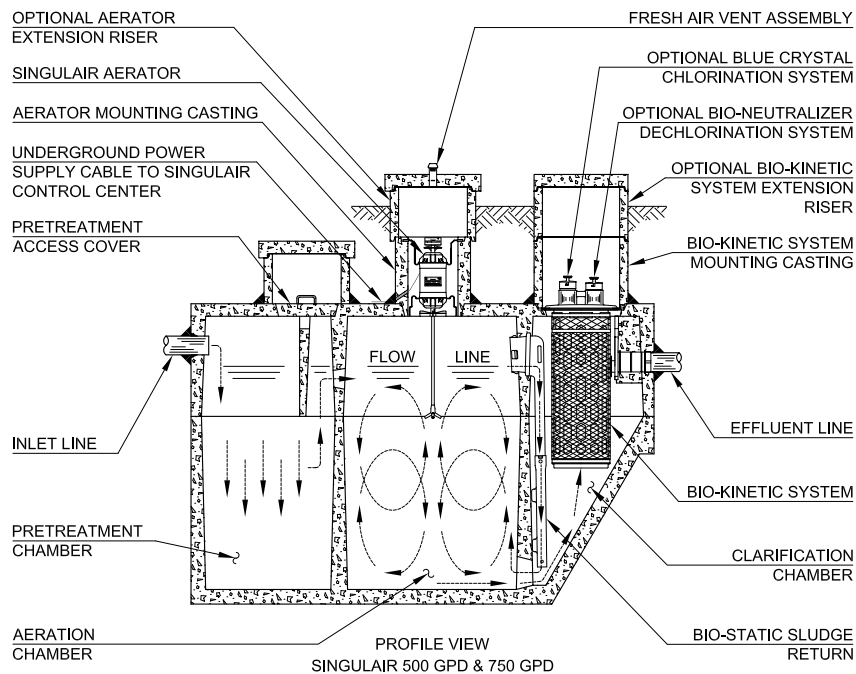

FEATURES AND ADVANTAGES

Singulair tanks, access risers and covers are reinforced precast concrete, manufactured by the licensed Norweco distributor. Internal walls and baffles are cast-in-place to insure uniformity and maximum strength. All components within the system that will contact the wastewater and provide treatment are constructed entirely of molded plastic, stainless steel or rubber.

The Singulair aerator is powered by a 1725 RPM, 115 volt, 60 hertz, single-phase, fractional horsepower motor. It is the only electrically powered component in the Singulair system. The aerator has been designed specifically for use in the Model 960. It costs less to operate and consumes fewer kilowatt hours of electricity than most major appliances.

Singulair aerators are supplied with a prewired electrical control center contained in a corrosion resistant enclosure. The control center contains the Singulair time clock and selector switch that control aerator operation. The local distributor's name, address and telephone number are displayed on the control center cover.

All system controls and necessary owner information are conveniently located at your fingertips.

Non-mechanical flow equalization and final filtration is accomplished within the Singulair tank by the Bio-Kinetic system. This revolutionary device is installed in the clarification chamber and connected to the system outlet. Optional chlorination and dechlorination may be included in the Bio-Kinetic system if required. All Singulair components work together to assure complete pretreatment, aeration, clarification and final filtration.

SINGULAIR® SYSTEM PERFORMANCE

Rivalling the performance of the most advanced wastewater treatment plants in the world, the Singulair Model 960 system complies with USEPA wastewater treatment guidelines for secondary treatment systems and meets all requirements of NSF/ANSI Standard 40. In ecologically sensitive areas, the most stringent effluent standards are 10 mg/L CBOD and 10 mg/L TSS. Rated Class I after successfully completing the 7 month Standard 40 test protocol, the Singulair Model 960 averaged effluent of 6 mg/L CBOD and 10 mg/L TSS.

OPERATIONAL REQUIREMENTS

The Model 960 Singulair system is designed to treat only domestic wastewater. Domestic wastewater is defined as the waste generated from a typical residence. This includes flows originating from: bathtubs, combination baths/showers, bidets, clothes washers, dishwashers, drinking fountains, water coolers, food grinders, kitchen sinks, lavatories, mop basins, service sinks, shower stalls, group showers, sinks, urinals, wash fountains, wash sinks, water closets and whirlpool baths. While the use of bio-degradable detergents is recommended, the Model 960 system has been designed to handle any reasonable amount of bathroom, kitchen or laundry waste. However, some care should be exercised to insure that non-biodegradable and/or toxic materials are not disposed of via the domestic wastewater plumbing. Do not use the plumbing system for disposal of lint, cooking grease, scouring pads, diapers, sanitary napkins, cotton balls, cotton swabs, cleaning rags, dental floss, strings, cigarette filters, rubber or plastic products, paints and thinning agents, drain cleaners or other harsh chemicals. These items could plug portions of the plumbing, interfere with biological treatment, accumulate in the treatment system and adversely affect system performance. Never connect roofing down spouts, footer drains, sump pump piping, garage and basement floor drains or water softener backwash to the domestic wastewater plumbing or the treatment system. Water softener backwash will interfere with biological treatment and must be disposed of separately.

ELECTRICAL REQUIREMENTS

Each Singulair control center must be wired to a dedicated 115 VAC, single-phase circuit at the main electrical service panel. A 15 amp circuit is recommended (10 amp minimum). A pictorial wiring diagram is provided inside the control center enclosure. All electrical work must be performed in accordance with the requirements of the National Electrical Code and all applicable local codes. Electrical connections should be made only by a qualified electrician following proper procedures and using safe tools.

CAUTION: Any time service is required, first shut off the dedicated circuit breaker in the main electrical service panel. Next, shut off the selector switch in the Singulair control center. Failure to do so could result in personal injury or equipment damage.

SINGULAIR® AERATOR

The aerator has been specifically designed for use in the Singulair system and includes special alloy and molded plastic parts to prolong aerator life. Aerator bearings are pre-lubricated and sealed. Singulair aerators are installed in a concrete mounting casting above the aeration chamber. Fresh air enters the aerator through the drip shield and is drawn down the hollow aspirator shaft where it is introduced below the liquid surface. Only the molded plastic aspirator and the lower portion of the stainless steel aspirator shaft are submerged.

The aerator is not designed to run under water and will automatically shut off if a high water condition occurs. If the liquid rises to the level of the foam restrictor, the control center circuit breaker will automatically open to shut off power to the aerator, light the red warning light and sound the audible alarm.

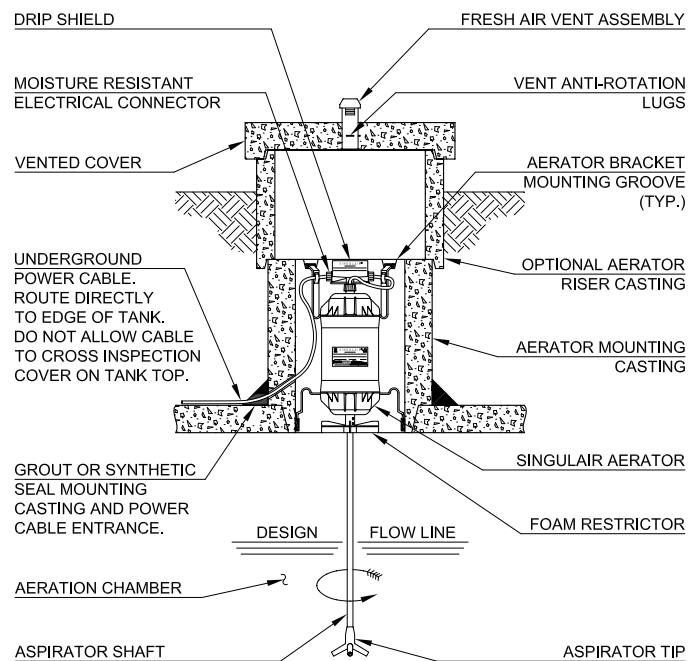

Each Singulair aerator is a precision engineered electro-mechanical device. Do not remove it from its installed position. Do not attempt any type of repair. Contact your local Singulair distributor if service is needed. Unauthorized tampering or repair will void important provisions of the limited warranty and exchange program.

FRESH AIR VENTING SYSTEM

An aerator vent assembly is cast into the concrete access cover above each aerator. The vent assembly supplies fresh air to the aerator, which is drawn through the aspirator and into the wastewater. Finished landscaping should be maintained six inches below the top of the vented access cover and graded to drain runoff away from the cover. Do not allow plants, shrubbery, mulch or landscaping of any type to restrict the flow of air to the vent assembly or obstruct the access cover.

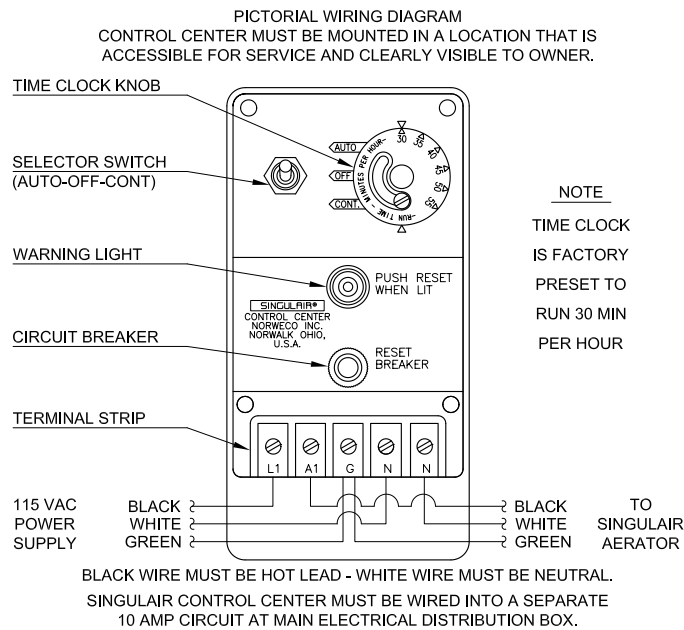

SINGLAIR® CONTROL CENTER

Every Singlair aerator is supplied with a prewired electrical control center to permit fully automatic operation. The control center is contained in a sealed corrosion resistant enclosure for your safety and the protection of components and wiring. The control center should be located so the red warning light can be seen and the audible alarm heard. It should be mounted to minimize exposure to direct sunlight, freezing rain or conditions that might prevent routine inspection or access. If an electrical overload occurs for any reason, the red warning light will glow and the audible alarm will sound. To shut off the alarms and restart the aerator, push the reset button on the control center cover. This should reset the circuit breaker and allow the aerator to resume normal operation. If the alarms do not shut off after depressing the reset button or if the breaker continues to trip, call the local Singlair distributor.

TIME CLOCK

Each control center is supplied with an adjustable time clock that determines the operating cycle of the aerator. The time clock will not permit the aerator to run less than 30 minutes out of each hour and is adjustable in 5 minute increments up to 55 minutes per hour. Full time operation is achieved by moving the selector switch to the "continuous" position. The performance of the Singlair system has been certified to meet NSF/ANSI Standard 40 effluent quality requirements and USEPA secondary treatment guidelines at the minimum time clock setting. The time clock is factory preset and should not be adjusted by the owner. Your factory-trained Norweco distributor will make necessary adjustments under the specific direction and authorization of the local regulatory agency. If you feel an adjustment is necessary, contact your local distributor.

BIO-STATIC® SLUDGE RETURN

Each Bio-Static sludge return is securely installed in the aeration/clarification chamber wall to provide return of settled solids. Aeration chamber hydraulic currents enter the sludge return(s) and are directed through the Bio-Static device into the clarification chamber. The hydraulic currents containing resuspended sludge are directed through the clarification chamber inlet zone and back to the aeration chamber for additional treatment. The Bio-Static sludge return accomplishes resuspension and return of settled solids without disturbing the contents of the clarification chamber. It has no moving parts and does not require service but its operation will be checked by your local distributor during each semi-annual service inspection.

BIO-KINETIC® SYSTEM

Bio-Kinetic systems provide non-mechanical flow equalization through all plant processes. The Bio-Kinetic system contains 3 separate filtration zones, 8 independent settling zones, optional chlorination and dechlorination tablet feed systems and serves as its own chlorine contact chamber. When used with Blue Crystal residential disinfecting tablets, the performance of the Bio-Kinetic system as a chlorination device is certified to NSF/ANSI Standard 46, Section 11. All components are manufactured from plastic, stainless steel or rubber. Do not remove a Bio-Kinetic system from the clarification chamber without disengaging the locking lugs and pumping out the internal chambers. Your local distributor has the necessary training, tools and equipment for removal and cleaning. If your Bio-Kinetic system is in need of service contact your local distributor. During each semi-annual service inspection your local distributor will remove and clean the Bio-Kinetic system or replace it with a unit from their service stock.

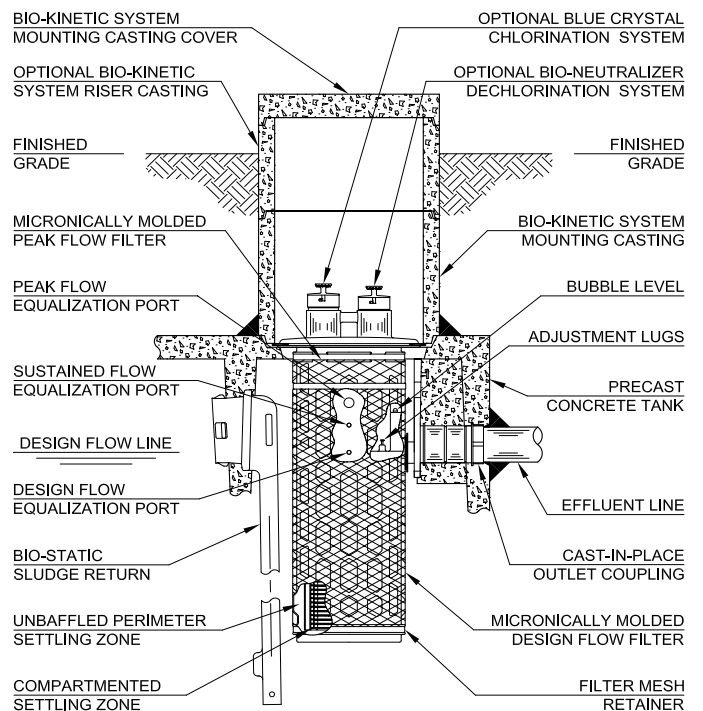

NON-MECHANICAL FLOW EQUALIZATION

The patented design of the Bio-Kinetic system provides non-mechanical flow equalization for the Singulair Model 960 wastewater treatment plant. Equalization reduces incoming hydraulic surges (e.g. typical shower of 10 minutes duration, bathtub discharge of 5 minutes duration, clothes washer discharge of 2 minutes duration and dishwasher discharge of 2 minutes duration) throughout the system. The flow equalization provided by the Bio-Kinetic system causes wastewater to be held upstream of the final outlet during hydraulic surges, which preserves treatment integrity and enhances system operation. The actual rate of equalization varies and depends upon specific loading patterns and the duration of each flow surge. At the design loading pattern like the one used during the NSF/ANSI Standard 40 performance evaluation, the Model 960-500 GPD system equalizes all flow an average of 48%. As a result, hydraulic surges and periods of high wastewater flow are automatically reduced to protect the environment and all treatment plant processes on a demand use, as needed, basis.

BLUE CRYSTAL® RESIDENTIAL DISINFECTING TABLETS

If local regulations require, an initial supply of Blue Crystal disinfecting tablets will be placed in the Bio-Kinetic system chlorine feed tube(s) at system start-up. Specifically formulated for use in the Singulair system, Blue Crystal disinfecting tablets provide efficient and reliable disinfection when effluent chlorination is desirable. Manufactured from calcium hypochlorite, Blue Crystal disinfecting tablets provide effective, economical bacteria killing power. Liquid entering the Bio-Kinetic system contacts the installed Blue Crystal disinfecting tablets, just downstream of the equalization ports. A fully charged feed tube will last an average of six months. During each semi-annual inspection, your local distributor's service technician will check system operation, the rate of tablet consumption and install tablets during routine service inspections.

NOTE: USEPA guidelines state "On the average, satisfactory disinfection of secondary wastewater effluent can be obtained when the chlorine residual is 0.5 ppm after 15 minutes contact." Retention time must comply with the controlling regulatory jurisdiction.

CAUTION: The improper handling of Blue Crystal tablets may cause personal injury or property damage. Keep out of the reach of children and do not allow the tablets or feed tube to contact skin, eyes, or clothing. Tablets may be fatal if swallowed and tablet dust is irritating to the eyes, nose and throat. Do not handle the tablets or feed tubes without first carefully reading the product container label, MSDS information and the handling and storage instructions. Mixing of chemicals may cause a violent reaction leading to fire or explosion. For additional information about Blue Crystal tablets contact your local distributor.

BIO-NEUTRALIZER® DECHLORINATION TABLETS

In environmentally sensitive areas, environmental regulations may require the use of Bio-Neutralizer dechlorination tablets. Manufactured as an efficient and dependable means to chemically neutralize both free and combined chlorine, Bio-Neutralizer dechlorination tablets provide consistent reduction or elimination of chlorine residual without unnecessarily reducing the level of dissolved oxygen in the treatment system effluent. Bio-Neutralizer dechlorination tablets utilize a unique chemical mixture for chlorine reduction and environmental protection. As liquid passes through the final discharge zone of the Bio-Kinetic system, the flow contacts the installed Bio-Neutralizer tablets and residual chlorine is removed from the system effluent. A fully charged Bio-Neutralizer feed tube will last an average of six months. During each semi-annual inspection, your local distributor's service technician will check system operation, the rate of tablet consumption and install tablets during routine service inspections.

CAUTION: Bio-Neutralizer tablets or feed tubes should not be mixed with Blue Crystal tablets. Do not handle the tablets or feed tubes without first carefully reading the product container label, MSDS information and the handling and storage instructions. For additional information about Bio-Neutralizer tablets contact your local distributor.

NO OWNER MAINTENANCE

The Singulair system is inspected and serviced by a local licensed, factory-trained distributor, therefore, no owner maintenance is required during the warranty period. The Singulair system does not require pumping as often as a septic tank. Under normal use only the pretreatment chamber should be pumped. How often pumping is necessary depends on system use. The local Singulair distributor will inspect the aeration chamber contents and plant effluent at six month intervals to determine if the pretreatment chamber is discharging excessive solids. Every three years, the pretreatment chamber should be inspected. The pretreatment chamber will normally require pumping at three to five year intervals. Contact your local distributor prior to tank pumping for complete information on removal of equipment, access to individual chambers, coordination of services and proper disposal of tank contents. A tank pumping service licensed by the local regulatory agency must be used for removal and disposal of tank contents. The tank pumper should consult with local authorities to determine the proper disposal method.

If a period of intermittent use, or an extended period of non-use of the Singulair system is anticipated, contact the local distributor for instructions. Your local licensed distributor has comprehensive Singulair service instructions and has been factory-trained in troubleshooting procedures. Contact your local distributor if you require service or information regarding tank pumping.

DISTRIBUTOR SERVICE PROGRAM

Semi-annual service inspections, at six month intervals for the first two years of system operation, are provided by your local Norweco distributor and are included in the original purchase price of the Singulair system. Costs for travel and labor are not charged to the owner. During an inspection, each mechanical aerator, Bio-Kinetic system and other plant components are serviced as outlined in the Singulair Service Manual. After the initial two year service program is completed, the local distributor will provide continued service at the owner's option. The service program should be renewed by the owner to insure maximum system performance.

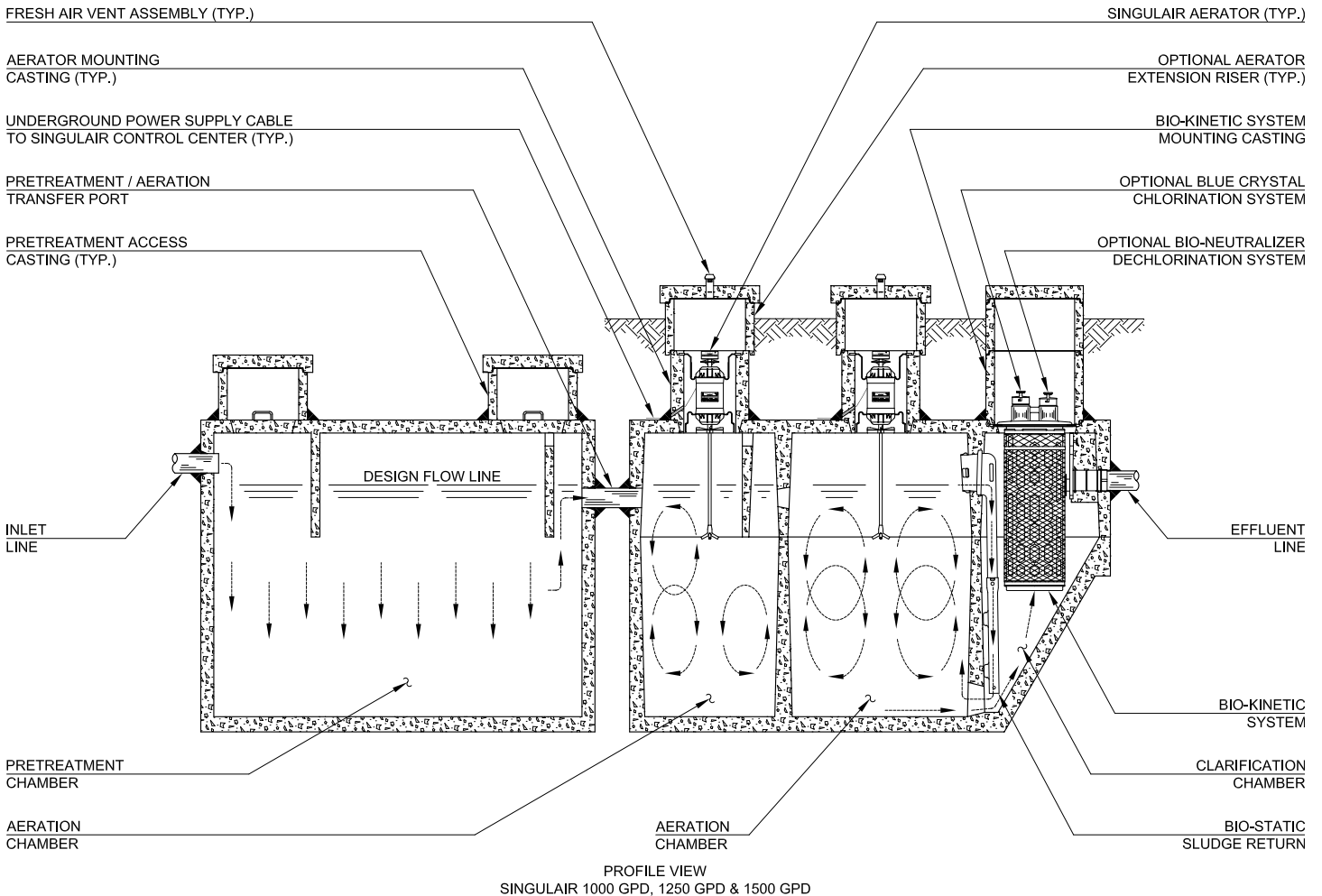

Ask your Norweco distributor about a renewable service contract. If you allow service coverage to expire, you can still obtain the professional assistance of a factory-trained technician. However, these special service calls will be performed on a time and materials basis. Professional service is important to proper system operation and should not be allowed to lapse. Be sure to consider the advantages of a renewable service contract.

The local Norweco distributor's service technician will perform the following services during each service inspection:

- ✓ Check aerator operation
- ✓ Check aerator power consumption
- ✓ Check aerator air delivery
- ✓ Clean stainless steel aspirator shaft
- ✓ Clean aspirator tip
- ✓ Clean fresh air vent in concrete cover
- ✓ Inspect aeration chamber contents
- ✓ Check operation of control center
- ✓ Adjust time clock when required
- ✓ Remove the Bio-Kinetic system
- ✓ Scrape the clarification chamber
- ✓ Inspect the Bio-Static sludge return
- ✓ Inspect outlet coupling
- ✓ Install a clean Bio-Kinetic system
- ✓ Fill Blue Crystal feed tube
- ✓ Fill Bio-Neutralizer feed tube
- ✓ Inspect effluent quality
- ✓ Inspect outlet line
- ✓ Inspect ground water relief point
- ✓ Inspect effluent disposal system
- ✓ Complete owner service record
- ✓ Complete health department notification
- ✓ Complete distributor service record
- ✓ Mail health department notification

